



NEOBOLT COLLAR CROPPER

CONTENT

1. Safety.....	2
2. Technical specifications.....	2
3. Package contents:.....	2
4. Cutter setup:	3
5. Cutter use	4
6. Tool disassembly.....	5
7. Tool assembly.....	6
8. Tool maintenance	7

NEOBOLT COLLAR CROPPER

1. SAFETY

- Before use, read and understand safety and operating instructions both the hydraulic equipment and the collar cropper tool.
- Always use eye protection when using this tool.
- Use of protective gloves is recommended.
- Avoid placing hands in potential pinch points, as tool will move while cutting.
- Verify that equipment is in good working condition and properly set up before using.

2. TECHNICAL SPECIFICATIONS

	Neobolt size				
	3/8"	12mm	12mm/ 1/2"	1/2"	5/8"
Cropper Assembly	65120-00061	65120-00060	65110-00059	65110-00054	65110-00055
Use with	Avdel AV5	Huck SF20	Avdel AV30	Avdel AV15	Avdel AV30
Hydraulic pressure (bar)	Alum: 190 Seel: 490	400	180	400	350
Cropper Stroke (mm)	30	50	41	32	41
Cropper weight (kg)	0.48	0.86	2.4	1	1.5
Cropper Dia/Length (mm)	27 / 108	38 / 71	60 / 150	43 / 98	48 / 118

3. PACKAGE CONTENTS

One Neobolt collar cropper assembly.

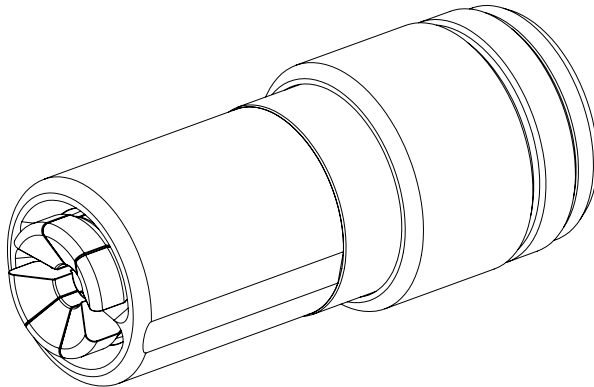

Neobolt cropper components:

			Neobolt size				
			65120-00061	65120-00060	65110-00059	65110-00054	65110-00055
	Item	Quantity	3/8"	12mm	12mm/ 1/2"	1/2"	5/8"
O-ring*	1	1	6510-00463	65110-00460	65110-00431	65110-00431	65110-00432
Jaw*	2	6	65110-00327	65110-00213	65110-00171	65110-00171	65110-00309
Cutter*	3	1	65110-00326	65110-00211	65110-00452	65110-00167	65110-00311
Jaw holder	4	1	65110-00328	65110-00212	65110-00451	65110-00172	65110-00310
Nut	5	1	65110-00329	-	65110-0454	65110-00291	65110-00313
Nose Hsg	6	1	65110-00330	-	65110-00453	65110-00173	65110-00312

* Typical wear items

4. CUTTER SETUP

Set pump to required pressure (See section 2 for required pressure)

Connect tool to hydraulic pump, use extension hose if required.

Mount cutter into hydraulic tool (See section 2 for tool selection)

- Remove o-ring from front of hydraulic tool.

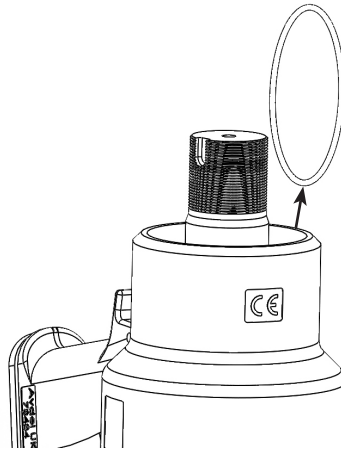

- Thread cutter clockwise (hand tight – Do not use wrench) into tool rod, until it bottoms out.

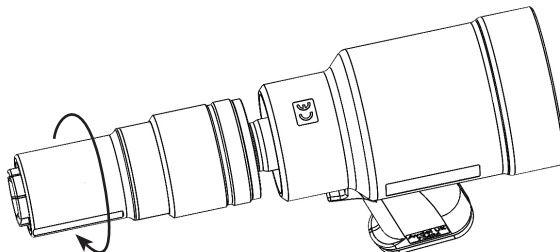

- Thread retaining nut clockwise into tool body (hand tight – Do not use wrench), until it bottoms out.

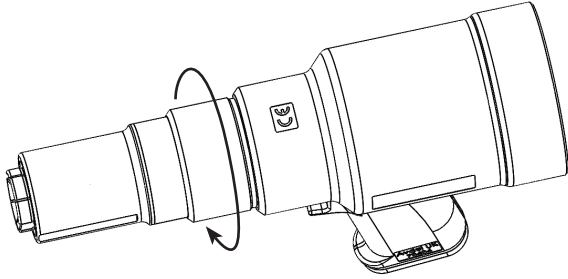

- Cycle tool twice and retighten retaining nut if needed.
- Verify that pintail from Neobolt pin fits inside the jaws.

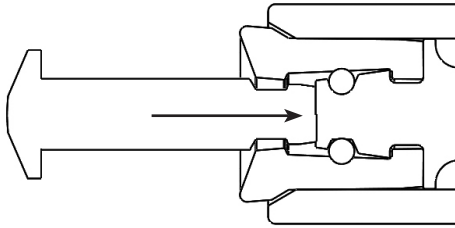

- Tool is now ready to use.

5. CUTTER USE

- Verify that pump pressure has been set to desired value
- Check tool to verify that jaws are intact and free of debris. Also check cutting surfaces for damage.

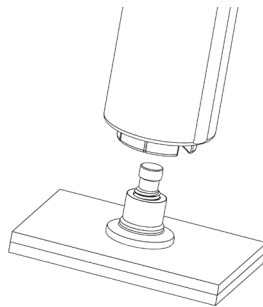
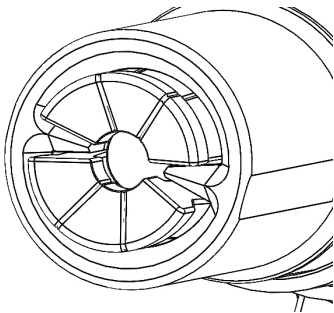

- Place tool against fastener to be cut. Pin tail must be fully inserted into cutter. Tool must be aligned with the fastener to be removed.

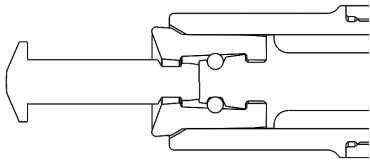

OK

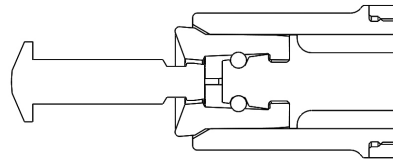

INCORRECT

- Press trigger to start cutting. Release button once collar is fully cut.

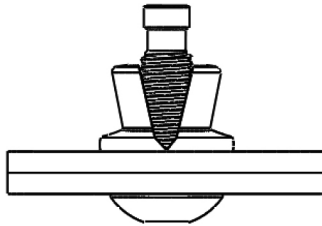

- Remove tool from fastener.
- Separate collar from pin to remove fastener.

6. TOOL DISASSEMBLY

- Unthread nose housing from cutter.

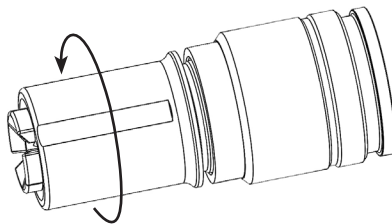

- Push jaw holder into cutter and slide out of the cutter. Jaws should fall out of cutter.

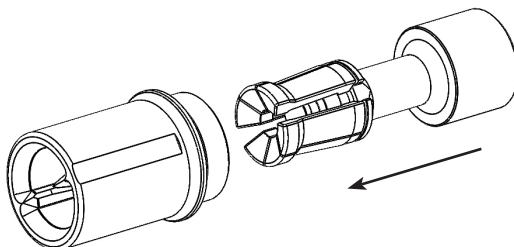

7. TOOL ASSEMBLY

- Slide o-ring into jaw holder as shown.

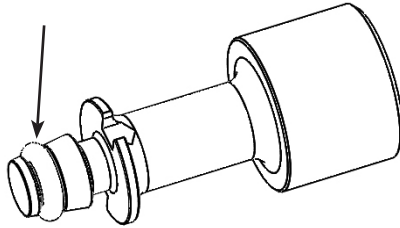

- Apply light coat of moly-lithium grease to inside of cutter.

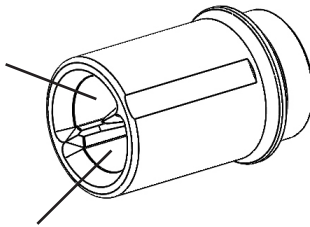

- Place jaws into jaw holder as shown, keeping them aligned with side grooves.

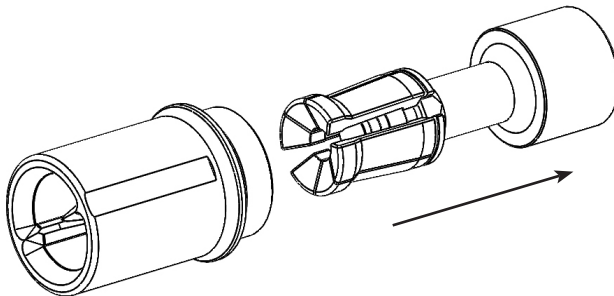

- Insert jaws and jaw holder into cutter, until jaws emerge out of the other side of cutter.

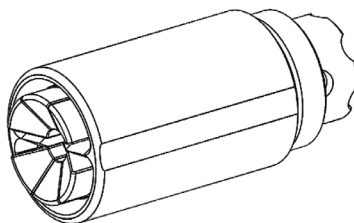

- Slide retaining nut into nose housing and thread nose housing (hand tight – Do not use wrench) into cutter.

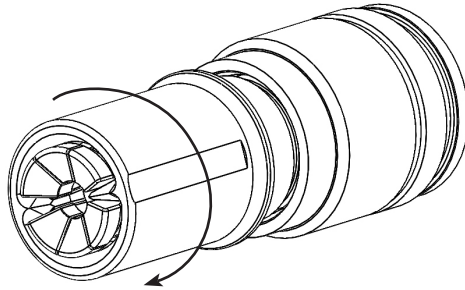

8. TOOL MAINTENANCE

For optimal performance, it is critical that the tool is kept clean and in good working order. Cleaning frequency will depend on usage and operating conditions.

To clean tool:

- Disassemble tool.
- Clean components. Inspect for damage and replace any damaged components.
- Apply a light coat of moly-lithium grease to inside of cutter using a cotton swab.
- Reassemble tool.



STANLEY Engineered Fastening

4 Shelter Rock Lane
Danbury, Connecticut,
United States, 06810
Tel. 877 364 2781
Fax 800 225 5614



Holding your world together®

Find your closest STANLEY Engineered Fastening location on
www.stanleyEngineeredFastening.com/contact
For an authorized distributor nearby please check
www.stanleyEngineeredFastening.com/econtact/distributors

Manual Number	Issue	C/N
65124-00007	A	20242

© 2020 Stanley Black & Decker, Inc.

Avdel®, Avex®, Avibulb®, Avinox®, Avseal®, Bulbex®, Hemlok®, Interlock®, Klamp-Tite®, Monobolt®, POP®, ProSet®, Stavex® and T-Lok® are registered trademarks of Stanley Black & Decker, Inc. and its affiliates. The names and logos of other companies mentioned herein may be trademarks of their respective owners. Data shown is subject to change without prior notice as a result of continuous product development and improvement policy. Your local STANLEY Engineered Fastening representative is at your disposal should you need to confirm latest information.